

NT Series

Current Sensors

Magneto-Resistive Current Sensors for Peak Currents up to 150 A

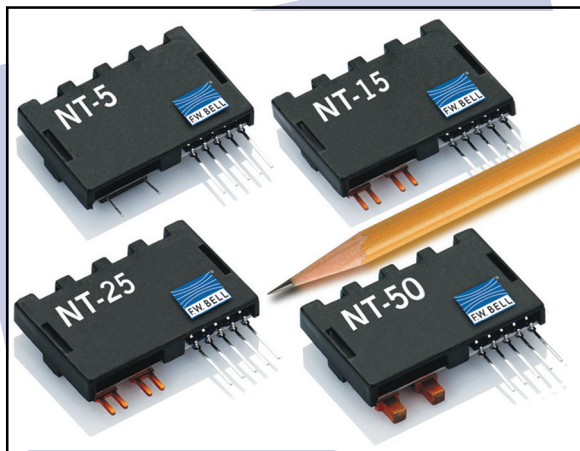

- ☀ Excellent Accuracy
- ☀ No Field Concentration
- ☀ Small and Compact Design
- ☀ Same Shape for all Current Ranges



Magneto-Resistive Current Sensors

The global miniaturization of electric systems in modern industrial applications is setting new challenges regarding the cost and size of electronic components and sensing devices. With NT Series current sensors from **F.W. Bell**, a surface of only 2.6 cm² on a printed circuit board is necessary for a potential free and galvanically isolated measurement of DC, AC and impulse currents up to 150 Apk. Due to the high sensitivity of the anisotropic magneto-

resistive (AMR) effect, there is no need for a magnetic field concentrator around the primary conductor. Therefore, no remanence occurs. The small weight of the NT Series is another advantage compared to conventional current measurement methods. The high overall accuracy is partially given by the measurement resistor that is integrated in the system. The output voltage, measured across that resistor, is directly proportional to the primary current.

The MR Effect

In thin films of permalloy (Fe-Ni) material, the electrical resistance changes when an external magnetic field is applied in the plane of the film. This change is due to the rotation of the film magnetization. The variation of the resistance due to an external field is called the anisotropic magneto-resistive (AMR) effect. Due to a special design of the chip, the resistance change is proportional over a wide range of measured field.

Current Measurement with MR

The operating principle of F.W. Bell NT current sensors is based on a differential magnetic field measurement with compensation (Fig. 1). The primary current is fed through a U-shaped conductor, creating a field gradient H_{prim} between the two sides of the conductor. The thin film magnetoresistors are placed on a silicon chip and connected in a Wheatstone bridge. The chip is mounted together with the analog interface electronics on a single in-line hybrid circuit. In order to obtain a high linearity (0.1%) and a low temperature sensitivity, a current I_s is fed back to the sensor chip through a compensation conductor located above the magnetoresistors. The resulting field H_{comp} exactly compensates H_{prim} , so that the sensors always work around a single operating point. At the output of the sensors, the compensation current flows through a measurement resistor R_M . The output voltage, measured across that resistor, is $V_{OUT} = \pm 2.5V$ at $\pm I_{PN}$. The nominal current is only determined by the geometry of the primary current conductor.

Wide Measurement Range

The NT Series is made of four different sensors with nominal currents of 5, 15, 25 and 50 A, respectively. Each sensor can measure up to 3 times the nominal current for a period of 3 seconds. The NT Series has been designed for the measurement of DC, AC and impulse currents from a few milliamperes up to 150 A. The isolation voltage between the primary current conductor and the interface electronics is 3.5kV_{eff} (50/60 Hz for 1 min.).

Small and Compact Design

The sensitivity of MR sensors is almost 50 times higher than that of Hall sensors. A concentration of the measured magnetic field around the primary conductor with a ferrite or iron core is therefore not necessary. This results in very small and light weight (4g...6.5g) current sensor microsystems. The surface used by the NT on the PCB board is only 35 x 7.3 mm². This corresponds to approximately 1/3 of the surface required by conventional current sensors available on the market.

High Accuracy

The basic accuracy of the NT is 0.3% of I_{PN} . Since no field concentration is used, F.W. Bell current sensors have no remanence. This positively affects the overall accuracy. Since the output of the NT product family is a voltage, the error of the measurement resistor R_M is already included in the overall error of 0.8% (basic accuracy X + offset voltage V_O + error of the measurement resistor R_M) at I_{PN} and room temperature.

Large Spectrum of Applications

The NT Series offers a cost effective solution for current sensing in a variety of standard as well as custom specific industrial applications.

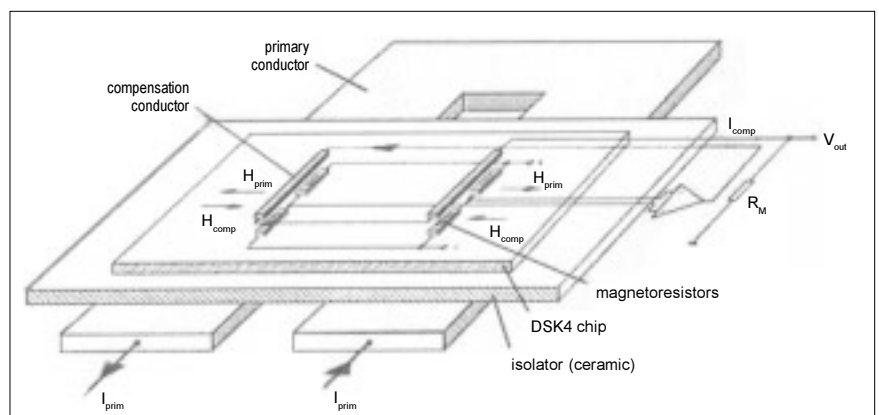

The easy through-hole mounting in a printed circuit board and the small footprint are significant advantages in applications like servo or 3-phase current drives as well as frequency inverters for DC drives. Other applications include mains adapters, uninterrupted power supplies, battery powered applications, building control and automation. Whenever DC, AC and impulse currents have to be measured, F.W. Bell current sensors are there.

Magneto-Resistive Current Sensors

For the potential free measurement of electric currents (DC, AC, impulse...) with the magneto-resistive (AMR) technology. The nominal currents are 5, 15, 25 and 50 A, with a galvanic isolation between the primary current and the output signal.

Applications

- 3 phase current drives and servo drives
- Frequency inverters for DC drives
- Mains adapters
- Uninterruptable power supplies
- Battery powered applications
- Solar technology
- Building control and automation
- Welding equipment

Advantages

- Excellent accuracy, linearity and dynamics
- Small and compact design
- Light weight (0.14...0.23 oz)
- Small sensitivity to interferences
- Internal measurement resistor R_M
- No field concentration, therefore no remanence

	Unit	NT-5	NT-15	NT-25	NT-50	
Electrical Data	Primary nominal current, I_{PN}	A	5	15	25	50
	Primary current measurement range ¹	A	0... ± 15	0... ± 45	0... ± 75	0... ± 150
	Overload ²	A		10 X I_{PN}		
	Output voltage at ± I_{PN}	V		± 2.5		
	Internal resistor of the NT	Ω		< 150		
	Supply voltage ± 5% ³	V		± 12... ± 15		
	Power consumption @ I_{PN}	mA		< 40		
	Resistance of the primary conductor	mΩ	< 12	< 1	< 0.5	< 0.15
	Isolation test voltage, effective	kV		3.5		
	Measurement tension ⁴	V		600		
Accuracy	Accuracy ⁵ at I_{PN} and room temp.	%		< ± 0.3		
	Overall accuracy at I_{PN} and room temp.	%		< ± 0.8		
	Linearity	%		< ± 0.1		
	Typical offset voltage at room temp.	mV		± 7.5		
	Sensitivity drift ⁶	%/°C		± 0.01		
	Max. offset over temp. (- 25°C... + 85°C)	mV		± 35		
Dynamic Data	Reaction time (10% of I_{PN})	μs		< 0.15		
	Rise time (10%... 90% of I_{PN}) ⁷	μs	< 1.7	< 1.7	< 1.2	< 1.0
	Frequency range (deviated amplitude)	kHz		DC... 100		
General Data	Temperature range	°C		- 25°C... + 85°C		
	Storage temperature	°C		- 25°C... + 100°C		
	Mass	g (oz)	4.0 (0.14)	4.2 (0.15)	4.5 (0.16)	6.5 (0.23)
	Dimensions	mm (in)	35 x 23.5 x 7.3 (1.4 x 0.92 x 0.29)			
	Surface on PCB board	mm ² (in ²)	256 (0.4)			
	Isolated, self-extinguishing housing material		UL 94-VO			
	Standards		EN50178 • EN61010 • CE-sign			

NOTES: ¹ For 3 s; $I_p = 2 \times I_{PN}$ for 10 s

² For 20 ms, then 20 s max. I_{PM}

³ At $V_s = \pm 12$ V; $I_p = 2 \times I_{PN}$. Restrictions on accuracy and dynamic range

⁴ Pollution degree 2, cat. II

⁵ Without offset V_o and tolerance error of the measurement resistor R_M

⁶ Only dependent of the TC of the measurement resistor R_M

⁷ With $di/dt = 100$ A/μs

Mechanical Dimensions

Dimensions with drilling plans

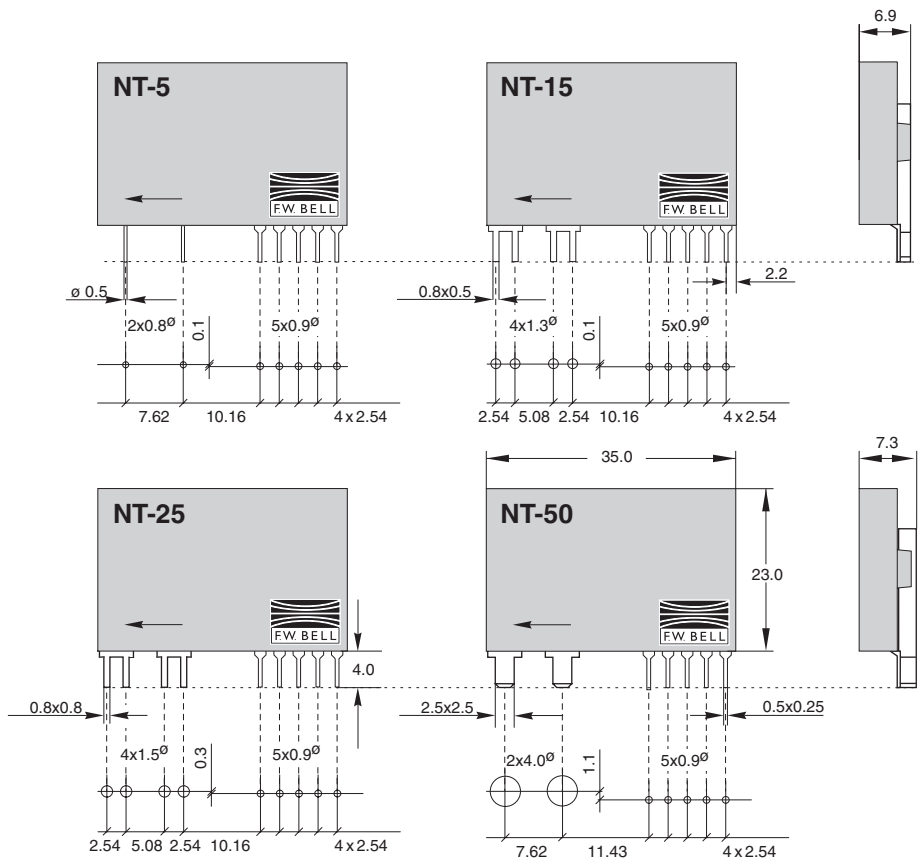

Recommended current path layout

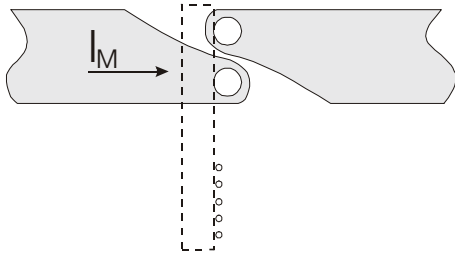

Recommended minimal distance

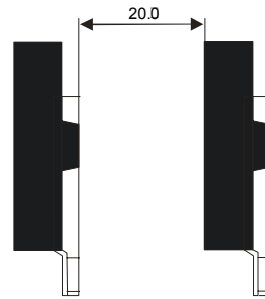

Pinning

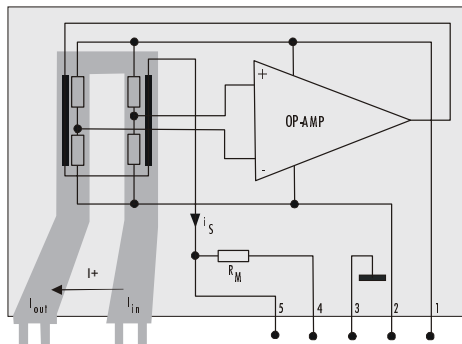

- Pin 1 = $+V_S$
- 2 = $-V_S$
- 3 = SUPPLY GND (PINS 3,4 SHOULD BE CONNECTED TOGETHER)
- 4 = OUTPUT GND
- 5 = V_{OUT}

- I_{in} = current input
- I_{out} = current output
- \leftarrow = positive current direction

All dimensions in mm

